

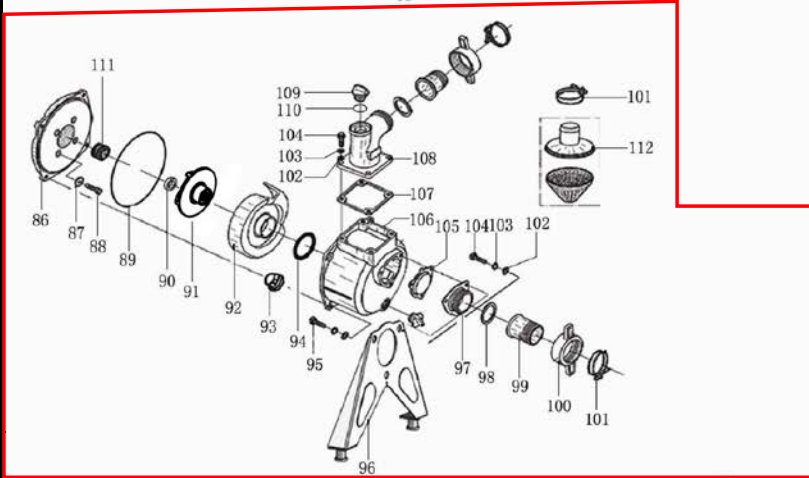

## GP40-II:0900:PARTY MARKETING GASOLINE PUMP SPARE PARTS LIST

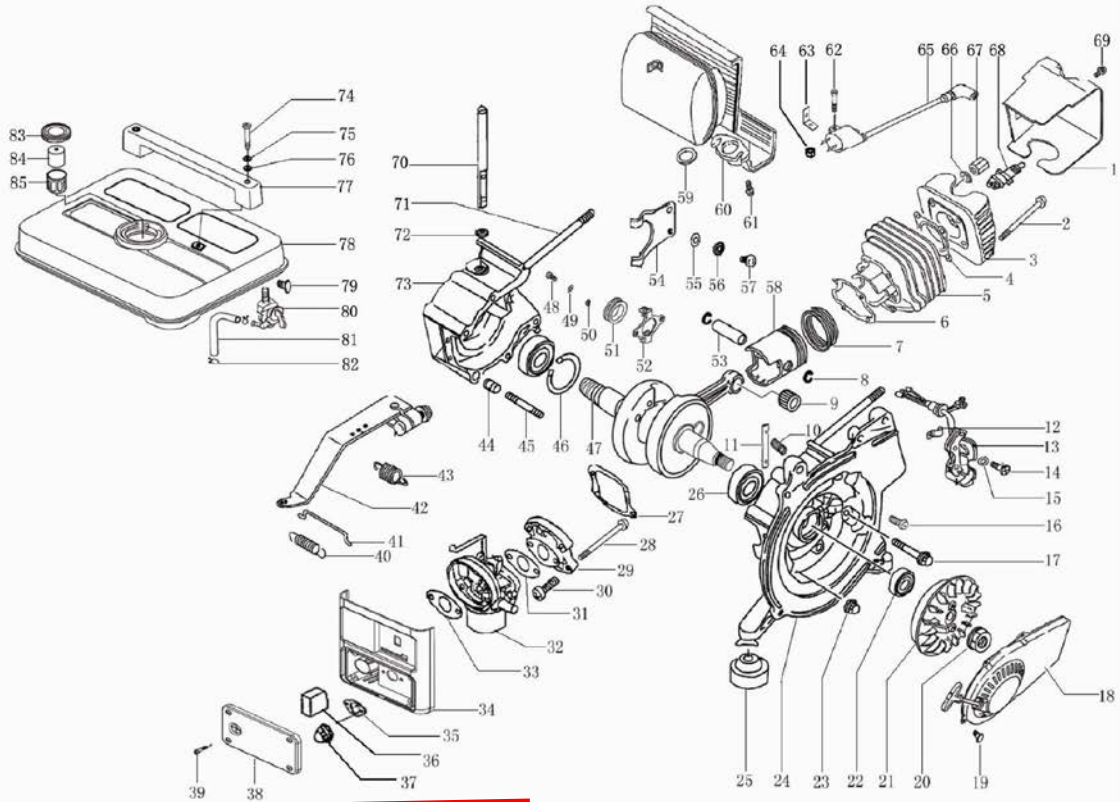

序号 No.	编号 CODE	名称 DESCRIPTION	英文名称 DESCRIPTION	数量 Qty.	备注 REMARK
1	022010001600	950气缸盖罩	cylinder head cover	1	
2	511050610501	六角法兰面螺栓-加大系列-B级M6X105	bolt,flange M6×105	2	
3	022010001500	950汽缸盖	cylinder head	1	
4	022010001200	气缸盖垫片	gasket,cylinder head	1	
5	022010001300	气缸	cylinder	1	
6	022010001400	气缸垫片	gasket,cylinder	1	
7	022010001100/022010001000	一道环/二道环	piston ring set	1套	
8	022010000700	950活塞销挡圈	circlip	2	
9	022010004800	滚针轴承K101413	roller bearing	1	
10	022010002400	压缩弹簧	spring,compression	1	
11	022010002300	950调速支持板	supporting plate	1	
12	022010001800	950点火器压线板	clamp	1	
13	022010001700	一体化点火器	integrative portfire	1	
14	515010601603	螺钉M6×16	screw M6×16	2	
15	513020600002	标准型弹簧垫圈6	spring washer Φ6	2	
16	515060604000	半圆头螺钉M6×40	screw M6×40	1	
17	511050604500	六角法兰面螺栓-加大系列-B级M6X45	bolt,flange	4	
18	022010400013	950手拉盘总成(黑)	recoil starter assembly	1	

19	511050601201	法兰螺栓M6×12	bolt M6×12	4	
20	512101000000	非金属嵌件六角法兰面锁紧螺M10	nut ,crankshaft M10	1	
21	022010300003	飞轮	flywheel	1	
22	522010100301	旋转轴唇形密封圈 (F) B2030	oil seal 20×30×7	2	
23	512040600002	带齿六角法兰面螺母M6	nut M6	2	
24	022010000200	曲轴右箱体	crankcase,front	1	
25	022010003400	减震垫	absorber	4	
26	521010010201	轴承6004	bearing 6004	2	
27	022010001900	进气阀垫片	valve base gasket	1	
28	516030606002	双头螺栓B型M6×60	stub M6×60	2	
29	022010500000	进气阀总成	intake reed comp	1	
30	511050602002	法兰螺栓M6×20	bolt,flange M6×20	4	
31	022010002000	进气口垫片	intake gasket	1	
32	022010600000	化油器总成	carburetor assembly	1	
33	022010002100	化油器垫片B	carburetor, plate B	1	
34	032010500000	控制面板 (1.5水泵)	control panel assembly	1	(汽油950水泵面板)
35	022010002200	化油器垫片A	carburetor, plate A	1	
36	032010000400	空滤	Air filter	1	
37	512040600002	带齿六角法兰面螺母M6	nut M6	2	
38	032010000500	控制面板盖	control panel cover	1	含在控制面板
39	515060501500	十字盘头螺钉M5*15	Screw M5*15	4	含在控制面板
40	022010002600	复位弹簧	spring,tension	1	
41	022010002500	拉杆	rod,link	1	
42	022010000500	调速臂	governor arm	1	
43	022010002700	调速弹簧	spring,governor	1	
44	514011001400	圆柱销-不淬硬钢和奥氏体不锈钢10X7X14	pin 10×7×14	2	
45	516030605004	双头螺栓B型M6X50	stud M6×50	2	
46	518014200001	A型孔用弹性挡圈	circlip	1	
47	032010200000	曲轴连杆总成 (1.5水泵)	crankshaft assembly	1	
48	511050601601	六角法兰面螺栓-加大系列-B级M6X16	bolt M6×16	2	
49	513020600002	标准型弹簧垫圈6	spring washer Φ6	2	
50	513010600002	平垫Φ6	plain washer Φ6	2	
51	022010000600	950调速滑环	collar bush	1	
52	022010100000	飞锤组件	weight comp	1	
53	022010000800	活塞销	piston pin	1	
54	022010000400	调速拨叉	governor fork	1	
55	513010600002	垫片Φ3	plate washerΦ6	2	
56	513020300004	标准型弹簧垫圈3	spring washer Φ3	2	
57	515010300800	十字槽小盘头螺钉M3X8	screw M3×8	2	
58	022010000901	活塞	piston	1	
59	022010003000	消声器垫片	gasket,muffler	1	
60	032010300000	消声器	muffler assembly	1	款式可选
61	511130601600	法兰螺栓M6×16	bolt,flange M6×16	2	
62	511050602002	M6*20螺栓	Bolt M6*20	1	
63	032010000200	高压包固定片	ignition coil assy seat	1	
64	512040600002	螺母M6	Nut M6	1	
65	022010003101	950CDI高压包 (不带EMC屏蔽帽)	ignition coil assy	1	
66	513010600002	平垫Φ6	washer,plate Φ6	2	
67	512060601801	六角厚螺母M6	nut M6	2	
68	022010003300	950火花塞(F5TC)	spark plug	1	
69	511050601201	法兰螺栓M6×12	bolt,flange M6×12	2	
70	022010000300	调速轴	governor shaft	1	
71	516030610005	双头螺栓AM6*100	stud AM6×110	2	
72	522010100101	旋转轴唇形密封圈 (F) B0612	oil seal 6×12×4	1	
73	032010000100	左箱体(1.5寸水泵)	crankcase,rear	1	
74	515060603002	十字槽盘头螺钉H型M6X30	screw M6×30	2	
75	513020600002	标准型弹簧垫圈6	washer,spring Φ6	2	
76	513010600002	平垫Φ6	washer Φ6	2	
77	022010003801	950提手柄	handle	1	
78	032010000307	1.6L燃油箱(黄)	fuel tank comp	1	
79	511050601201	六角法兰面螺栓-加大系列-B级M6X12	Bolt M6*16	4	
80	029019900703	汽油油箱开关总成-03	fuel tank cock assy	1	
81	029019900100	燃油管	fuel pipe	1	
82	029019900401	汽油机油管卡箍	pipe clip	2	
83	029019901101	机组铁油箱盖-01	cap assy	1	
84	022010004100	油杯	fuel cup	1	
85	029019900602	机组油箱过滤器-02	strainer	1	
86	039010102400	泵盖	Pump cover	1	
87	513010800099	橡胶垫圈φ16×φ8×φ2	rubber washer	4	
88	511050804001	六角法兰螺栓M8X60	Inner hex bolt M8x60	4	
89	039010100500	泵盖O形密封圈	O ring	1	
90	039010110200	机械密封圈(动环 陶瓷件)	porcelain seal	1	
91	039010102500	叶轮	water pump impeller	1	
92	039010102600	导流器	volute casing	1	
93	512040800001	带齿六角法兰面螺母M8	nut M8	2	
94	039010100900	导流器O形密封圈	O ring	1	
95	511050803503	六角法兰面螺栓-B级M8X35	flange bolt M8X35	2	
96	032010100000	水泵支撑架	Pump support	1	
97	039010101700	进水阀座	inlet flange	1	
98	039010102000	进出水垫片(密封环)	O ring	2	
99	039010102100	接管	pipe joint	2	

100	039010102200	塑料手柄(联接套)	joint grip	2	
101	039010102300	卡箍(紧固圈)	Rear housing	3	
102	513010800002	平垫圈φ8	washerφ8	11	
103	513020800002	弹垫圈φ8	spring washer φ8	11	
104	511050802501	六角法兰螺栓M8*25	bolt M8X25	9	
105	039010101600	拍门组件	check valve	1	
106	039010101000	泵体	housing of pump	1	
107	039010101800	橡胶垫片	rubber washer	1	
108	039010101900	出水弯头	outlet flange	1	
109	039010120200	螺塞	plug packing	2	
110	039010120100	螺塞O形密封圈	O ring	2	
111	039010110100	机械密封圈(静环)	Mechanical seal	1	
112	039010130000	滤网总成	filter net	1	